

# Spotters

## Lead Spotters & Accessories



- Engineered and fabricated to provide maximum strength-to-weight ratio for superior pile rig performance.
- Large-bore hydraulic cylinders provide smooth and easy pile positioning and maximum load capacity.
- Multi-segment design provides minimum retracted length for driving aft batters.
- Heavy-duty hydraulic lead rotators (optional on some models) provide precise pile positioning for compound batter piles.
- Rear pivot design (on some models) provides significant side-to-side movement for side batters to 1:4.
- Made in the USA by the industry's most technologically innovative manufacturer of foundation equipment since 1974.



# Spotters

## Lead Spotters & Accessories

### Model 105 Lead Spotter

The ICE Model 105 light-duty hydraulic lead spotter has a retracted length of only 12.8' yet extends to 37.8' via two hydraulic sections of 8' each and one manual extension of 9'. The moonbeam provides 6' total side-to-side movement (3' either side of center) for leveling. Total weight is 5,270 lbs. Hydraulic recommendations are 10 to 20 gpm @ 1500 psi.

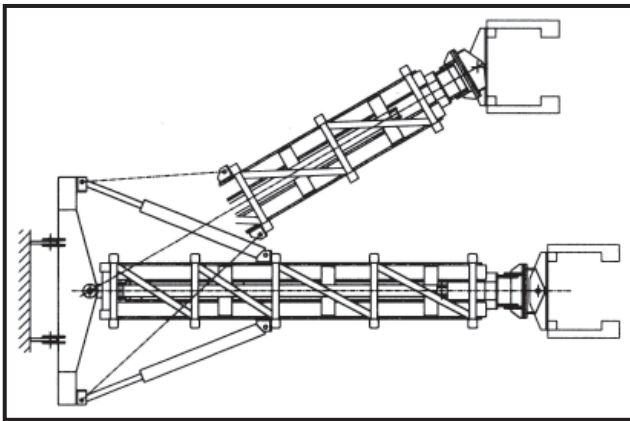
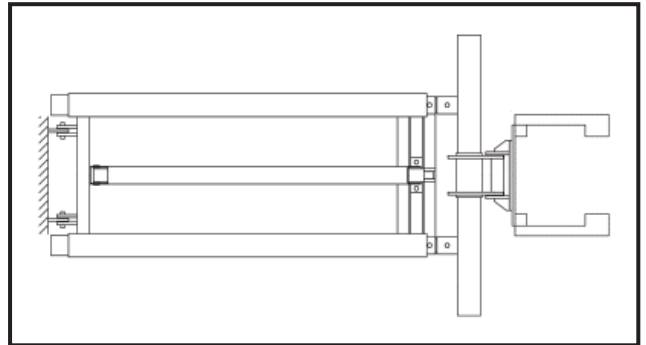

### Model 155 Lead Spotter

The ICE Model 155 medium-duty hydraulic lead spotter has a retracted length of 18.4' and extends to 38.4' via two hydraulic sections of 10' each. In addition, the rear cylinder design allows for 30° side-to-side movement (each way from center) for side batters up to 1:4. Total weight is 6,100 lbs. Hydraulic recommendations are 15 to 25 gpm @ 2000 psi. Options include a pin-on front lead rotator (not shown) for use with 3-axis leads.

### Model 225 Lead Spotter

The ICE Model 225 heavy-duty hydraulic lead spotter has a retracted length of 20.3' and extends to 40.3' via two hydraulic sections of 10' each. In addition, the rear cylinder design allows for 35° side-to-side movement (each way from center) for side batters up to 1:4. Total weight is 10,430 lbs. Hydraulic recommendations are 15 to 25 gpm @ 2500 psi. Options include a pin-on front lead rotator (shown) for use with 3-axis leads.

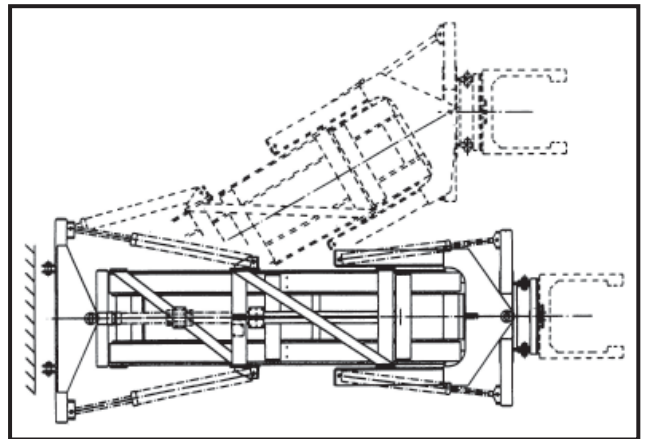

Spotters-50202

Also available:

- **ICE Model 12 auxiliary power unit** for spotter operation including 13 HP Honda gasoline engine providing 10 gpm @ 2000 psi. Dimensions are 27" x 18" x 26" H. Weight is 250 lbs.
- **ICE Model 25 auxiliary power unit** for spotter operation including 23 HP Cat diesel engine providing 24 gpm @ 2000 psi. Dimensions are 54" x 38" x 34" H. Weight is 1533 lbs.



**INTERNATIONAL  
CONSTRUCTION  
EQUIPMENT, INC.**

Corporate offices:

301 Warehouse Drive, Matthews, NC 28104

Tele: (704) 821-8200 or (888) ICEUSA1

Fax: (704) 821-8201

www.iceusa.com E-mail: sales@iceusa.com