

# Model 22-30

## Hydraulic Vibratory Driver/Extractor

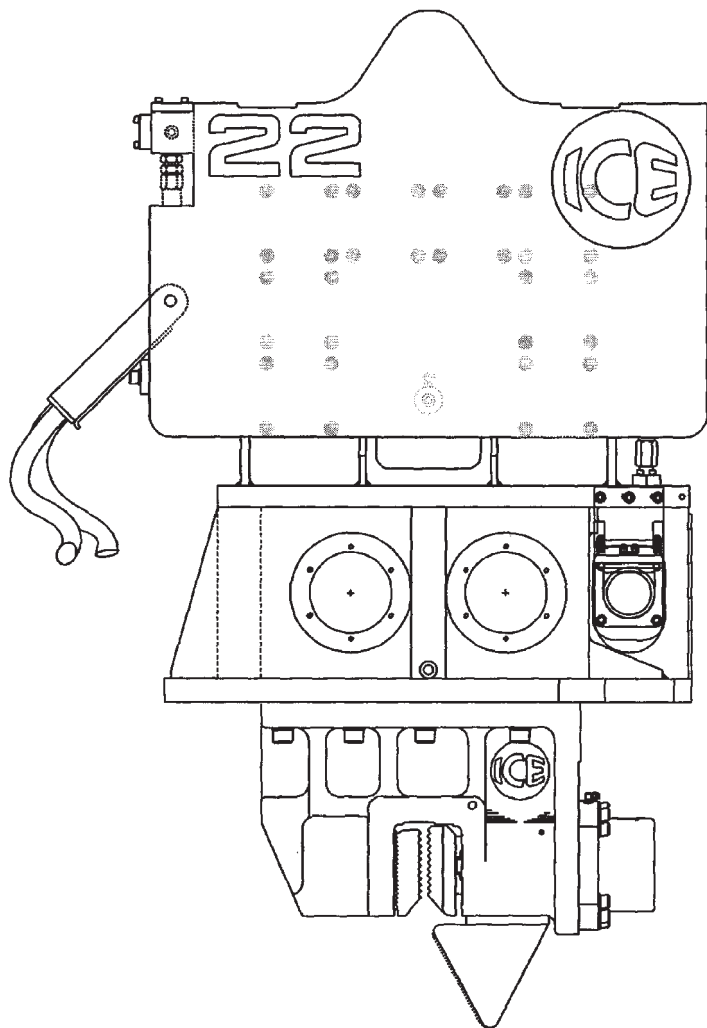

### Vibrator:

	Model 22-30	
Eccentric moment	2200 in-lbs	25 kg-m
Max frequency	1615 vpm	27 Hz
Centrifugal force	81 tons	725 kN
Amplitude (free hanging)	0.89 in	23 mm
Max line pull for extracting	54 tons	480 kN
Weight (no clamp or hoses)	7900 lbs	3583 kg
Non-vibrating weight	2960 lbs	1342 kg
Height (without clamp)	80 in	2032 mm
Length	76 in	1930 mm
Width	21 in	523 mm
Throat width	14.3 in	362 mm
Hydraulic hose length	150 ft	46 m
Hydraulic hose weight	1425 lbs	646 kg

### Power Unit:

	Model 335E	
Engine	Caterpillar C9	
Power	335 HP	250 kW
Operating speed	2200 rpm	2200 rpm
Max drive pressure	5500 psi	379 bar
Drive flow	91 gpm	344 lpm
Clamp pressure	4800 psi	331 bar
Clamp flow	6.3 gpm	24 lpm
Weight (w/ full fluid & fuel)	10455 lbs	4741 kg
Length	127 in	3226 mm
Width	64 in	1626 mm
Height	69 in	1753 mm
Hydraulic reservoir	275 gal	1041 liters
Fuel capacity	118 gal	447 liters

22-30-41228

### Hydraulic Clamps:

	Model 126C Universal Clamp	Model 127B Z-Pile Clamp	Model 80B Casing Clamps w/ 5' Beam	Model 55B Timber, Concrete & Pipe Clamp
Clamp force	125 tons (1112 kN)	125 tons (1112 kN)	160 tons (1423 kN)	53 tons (472 kN)
Weight	2185 lbs (991 kg)	3190 lbs (1447 kg)	2821 lbs (1279 kg)	4970 lbs (2254 kg)
Width	12 in (305 mm)	18 in (457 mm)	13.75 in (349 mm)	27 in (686 mm)
Height	38 in (959 mm)	41 in (1048 mm)	26 in (654 mm)	79 in (2007 mm)



**INTERNATIONAL  
CONSTRUCTION  
EQUIPMENT, INC.**

### Corporate offices:

301 Warehouse Drive, Matthews, NC 28104

Tele: (704) 821-8200 or (888) ICEUSA1

Fax: (704) 821-8201

www.iceusa.com E-mail: sales@iceusa.com