

WELDCO-BEALES MFG

EDMONTON, AB • LANGLEY, BC • BARRIE, ON • TACOMA, WA

WHEEL LOADER HIGH LIFT GRAPPLE

The WBM **High Lift Grapple** is ideal for loading and unloading shortwood in various applications. Due to extensive engineering and research, versatility is maximized, resulting in optimal production coupled with minimal service and maintenance. The grapple can also be customized to meet your exact specifications which means higher performance for the end user.

Features:

- Boom and grapple jaws fabricated with high strength alloy steel and are stress relieved for greater durability
- Grapple rotation achieved through heavy-duty sealed ball bearing, providing smooth rotation, longer service life and easy access to grease points
- Cylinder hoses and fittings well protected by steel guards
- Equipped with hydraulic timed jaw cylinders

Benefits:

- Maximum productivity
- Longer service life



EDMONTON, AB • 1-800-661-0378 | LANGLEY, BC • 1-800-665-0511
BARRIE, ON • 1-877-320-4286 | TACOMA, WA • 1-800-547-6357
www.weldco-beales.com



FEATURES AND SPECIFICATIONS

TYPE OF GRAPPLE: Shortwood Pulp Grapple

- 360° continuous rotation

Grapple Capacity:

- 4 1/2 yard Loader 1.4 cord
- 5 1/2 yard Loader 2.25 cord

Dimensions of Grapple:

- 4 1/2 yard Loader A: open - 123" closed - 88"
B: open - 62.5"
- 5 1/2 yard Loader A: open - 159" closed - 105.5"
B: closed - 84.5"

Boom Height:

- 4 1/2 yard Loader C: 28'
- 5 1/2 yard Loader C: 29'

Grapple Height:

- 4 1/2 yard Loader D: 17'3"
- 5 1/2 yard Loader D: 15'

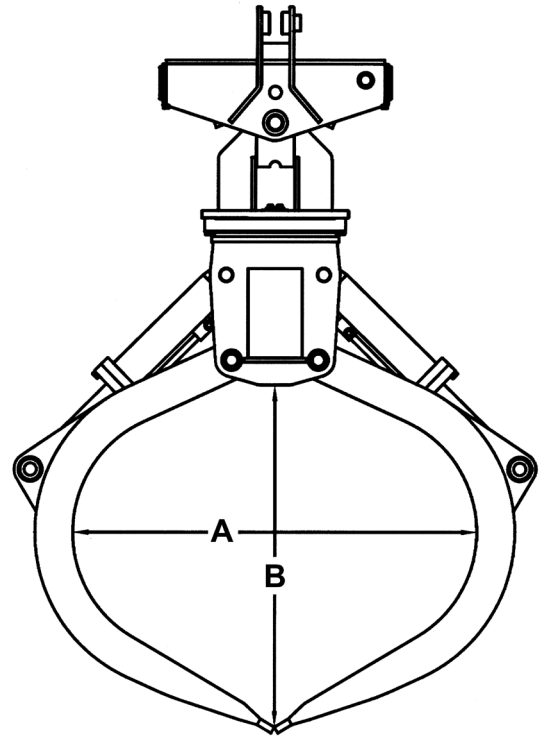

Dimensions and specifications are subject to change without notice. Dimensions and specifications listed are for reference only. Specific dimensions may vary.

